

V06

- 1, Del NFC PN7150, Add CON24, UART1 for GNSS or Debug, SPI2 to CON24, UART2 for BT
- 2, Move SMC_BOOT0 to Page 22, TP6.
- 3, HKs Add Pull-up Resistor, And add Read state GPIO.
- 4, TYPE-C U27 LSX no connect.
- 5, Correct Y2, Y3 Connect.
- 6, Add Voltage Test Point, >40 point
- 7, Add SIM DET D6.
- 8, CAMERA Modify. Add LDO for DVDD 1.2 and 1.05.
- 9, TFT con Modify.
- 10, STM32 PA10 NC. UART add Pull-up R108, R135

V07

- 1, UART1 to LSX, UART2 to GNSS, UART4 to bt, SPI1 to CON24
- 2, U329 I9PIN add Pull-up R229 .

V08

- 1, UART2 to LSX
- 2, HW state IO add resister. R48, R66, R145
- 3, 4G, WIFI ant CON add Debug L,C
- 4, Add shielding Case Hold.
- 5, DEL F12, Modified IO U329 for L9 layer to GND.
- 6, INT_M/A/G, NFC_EN, NFC_IRQ modified IO to E1 for L2 to GND
- 7, ADD R232

V09

- 1, AUX_P, AUX_N swapped.
- 2, Add R236.
- 3, Del R153
- 4, LED_G to 8M D3 pin. NFC_IRQ to 8M E1 pin, INT_M/A/G to 8M L4 pin.
- 5, R122,R58 to 27K, R123 to 47K.
- 6, 4G used SA16. ADD u5

V091

- 1, U5 8pin to SA11_TXD5, 9pin to SA11_RXD5.
- 2, ADD U7 for CAM_AFVDD, 2.8V 120mA.
- 3, U2 modified USB2642

V092

- 1, BOOT Resistor Modified.
- 2, EMMC 32G.
- 3, U3 NC.
- 4, PWM IO modify. MOTO E6, PMIC_5V T7, LED_B K6.

V093

- 1, R830 NC, R811 10k.

V094

- 1, BAT CON Modified for 1000 times.
- 2, ADD L66 L67

V095

- 1, R115 Modified to 200.

V096

- 1, ADD R153 for TPS65983B Slave.
- 2, Modified LM36922 to I2C3, J10 to I2C4.

V097

- 1, CHG_STATUS_B connect Red LED.
- 1, Add N-mosfet Q8 on SD2_NCD.
- 2, TPS65982 LDO_1V8D Connected BUSPOWERZ.
- 3, VDD_3V3 add 4x22uf C231....
- 4, VSYS_3V4_4V3 add 7x22uf C281....
- 5, U27 TPS65982 F2 UART_RX 100k R223 connect GND.
- 6, Add NET BT_WAKE
- 7, AUDIO_POWER_KEY connect Q2 PIN1.
- 8, ADD U68 NTSX2102
- 9, BOOT_CFG PU to NVCC_SNVS_3V3
- 10, R176 PU to NVCC_SNVS_3V3
- 11, R104 10 value.
- 12, R82 0402 0.1%
- 13, R934 100K
- 14, U2 USB2642 27,28 connect GND, 26 connect VDD.
- 15, ADD Q9, Modified WIFI_REG_ON, BT_REG_ON.
- 16, ADD R238 UART2_RXD PU USB_PD_LDO3V3
- 17, ADD Q10, R239, R240, R241
- 18, Add TYPEC_HRESET,
- 19, R42 1M ,
- 20, U147 connect TPS65982
- 21, SW3,SW5,SW7 2-3PIN
- 22, J50 modified
- 23, J12 modified

V098

- 1, 0 ohm jumpers SPI.
- 2, C181 NC
- 3,main board usb 2.0 connector
- 4,PFET pull up UART2_RX
- 5,red LED powered by VSYS
- 6, TPS65982 I2C2 10K pull-ups
- 7, TPS65982 remove_usb 2.0
- 8, TP34 connect USB_VBUS for test
- 9, SPI MISO ADD pull-up 10K
- 10, ADD u50,U51, C335,C336



V099

- (11) Battery connector (J20): changed to P / N: BA32-111203-01 3pin
- (12) Cancel J50 (flash holder) and move the flash to the rear camera FPC
- (13) change J22 to P / N: OK-06F034-04
- (14) J9 smartcard (80500122) is changed to SA070112150-105
- (15)Headphone socket (J2) changed to JA-36A1-111
- (16)
- (17) SIM +TF Card changed to SA2101110135-103-01, TF_NCD and 4G_SIM_((change to plastic tray)
- (18)R166, R109 changed to OR
- (19)Connect SMC_Boot0 to D7 pin of imx8mq
- (20)R41 (47K) changed to OR
- (21)ADD CLOCK Crystal (Y1)VALUE:32.768K 10pF ±20ppm
- (22)Use TLV75801PDBVR instead of LCDL015MR for U21 and U37
Make R33=11.8k Ω
Make R70=9.09k Ω
Remove R234 (0 Ω)
- (23) add a test point to pin C2 of the TPS65982 (U27's GP101_CFG0)
- (24) add inverter (Q12)
- (25) ADD C339
- (26)ADD C351/352/356/388/396/397/398/399/400/406/407/408/409/410/411/412/413/414/415/416/417//418/419/420/421/422/423/424/427/4287/429/430/431/432/433 1UF 6.3V 0201
- (27) C434 C435 NC
- (28) ADD C436/437/439/440/441/442/443/444 0201/1UF
ADD: C448 C449 C450 22UF 0603 6.3V
- (29) R209 R210 changed to 1.5K
- (30) DEL R1903
- (31) ADD: LNA BA725L6 & SAW filter B39162B4327P810, etc
- (32)Bring USB_PD_LDO3V3 to pin 23 of J12 on the main board:
- (33)Remove TVS11, TVS30, TVS31, and TVS32 on the main board:
- (34) C343/C377 changed to 220PF
- (35)change the connection of PMIC(U1) Pin49
- (36)Change U101 MIP1_VDDHA3 connection
- (37) R63/ R64, /R100/ R103 NC.
- (38) C379 and C380 = 100nF (0.1uF)
- (39) ADD R251/R252 1M
- (40) ADD :Y2 (32.768K)/C332/C333(6.8PF)
- (41) ADD :R253/NC
- (42) ADD R254/O OHM
- (43) Add connection between J4's pin12 and U101's G6
- (44) add R255/O ohm
- (45) C87/C256 changed to 56pF
- (46) ADD C451/C454 56pF

V1.02

1. Q12 CHANGE TO BSS138PW
2. R5 CHANGE TO I8R
3. D10 change to PTVS16VSLUR (USB Board)
4. ADD PTC FUSE -400CC1296L8-C (USB Board)
5. DEL R180, R184
6. ADD L9
7. ADD D25(NSR20F30K1T5G);
8. The connection network of R2 and R3 is changed to mvcc_snvs_3v3
9. The 33 and 34pin of PMIC increase 0 ohm resistance (R259/R260)
10. D6 changed to 0 ohm resistor (R261)
11. R55 and R218 connect to VDD_1V8
12. Add Q13, R263 and related networks
13. 322pin of U181 is connected to TF_NCD
14. C736 Change to 22uF
15. C740 Change to 10uF
16. J12 PIN define have changed.
17. The value of R118,R126 change to 18R, the value of R132 change to 100R

GNU GPLv3+
Copyright 2020
Purism SPC

Purism

Drawing Title: Librem 5		
Page Title: VER note		
Rev: v1.0.2	Date:	Design by: Sheet 1 of 21

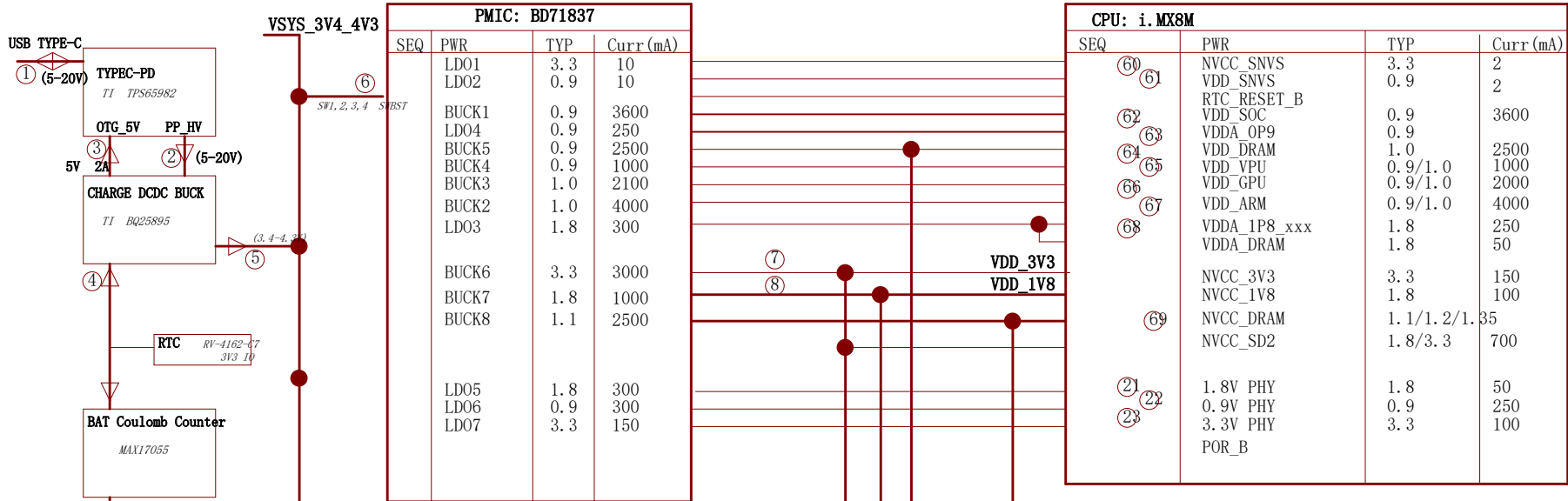

PMIC: BD71837			
SEQ	PWR	TYP	Curr (mA)
LD01	3.3	10	
LD02	0.9	10	
BUCK1	0.9	3600	
LD04	0.9	250	
BUCK5	0.9	2500	
BUCK4	0.9	1000	
BUCK3	1.0	2100	
BUCK2	1.0	4000	
LD03	1.8	300	
BUCK6	3.3	3000	
BUCK7	1.8	1000	
BUCK8	1.1	2500	
LD05	1.8	300	
LD06	0.9	300	
LD07	3.3	150	

CPU: i.MX8M			
SEQ	PWR	TYP	Curr (mA)
60	NVCC_SNVS	3.3	2
61	VDD_SNVS	0.9	2
62	RTC_RESET_B		
63	VDD_SOC	0.9	3600
64	VDDA_OP9	0.9	
65	VDD_DRAM	1.0	2500
66	VDD_VPU	0.9/1.0	1000
67	VDD_GPU	0.9/1.0	2000
68	VDD_ARM	0.9/1.0	4000
68	VDDA_IP8_XXX	1.8	250
68	VDDA_DRAM	1.8	50
69	NVCC_3V3	3.3	150
69	NVCC_1V8	1.8	100
69	NVCC_DRAM	1.1/1.2/1.35	35
69	NVCC_SD2	1.8/3.3	700
21	1.8V PHY	1.8	50
22	0.9V PHY	0.9	250
23	3.3V PHY	3.3	100
	POR_B		

i.MX8M				
	NVCC_x			
	_JTAG	3V3	VDD_3V3	JTAG
	_NAND1	1V8	VDD_1V8	
	_NAND2	1V8	VDD_1V8	
	_SAI1_1	3V3	VDD_3V3	BOOT
	_SAI1_2	3V3	VDD_3V3	BOOT
	_SAI2	1V8	VDD_1V8	AUDIO
	_SAI3	1V8	VDD_1V8	BT
	_SAI5	1V8	VDD_1V8	4G
	_GPIO1	3V3	VDD_3V3	
	_GPIO2	3V3	VDD_3V3	
	_I2C	1V8	VDD_1V8	_I2C2, 3, 4
	_UART	3V3	VDD_3V3	SC Card GPS
	_ECSPI	3V3	VDD_3V3	SPI FLASH BT
	_SD1_1	1V8	VDD_1V8	EMMC
	_SD1_2	1V8	VDD_1V8	EMMC
	_SD2	1V8	VDD_1V8	WIFI
	_ENET	1V8	VDD_1V8	

I2C				
I2C1	PMIC	BD71837	0x08	3V3 55*
	TYPE-C-PD	TPS65983B	0x0F	3V3 B1*
	RTC	RV-4162-C7	0x68	3V3
I2C2	Light	VCNL4040	0x60	1V8
	FLASH	LM3560	0xA6, 0xA7	1V8
	AGM sensor	LSM9DS1	0x6A, 0x1E	1V8
	TFT BAIS	TPS65132S	0x7C	1V8
I2C3	CAMERA1		0x20, 0x21	1V8
	TP		0x70	1V8
	CODEC	WM8962	0x34	1V8 G3*
	BackLight	LM36922	0x36	1V8
I2C4	BAT	MAX17055	0x36	1V8
	CHARGE	BQ25895	0x6A	1V8
	CAMERA2		0x20, 0x21	1V8
	EXT CON			1V8

Purism

Drawing Title: **Librem 5**

Page Title: **POWER TREE**

Rev: **v1.0.2** Date: Design by:

Sheet 2 of 21

VSYS_3V_4V2

DCDCBUCK
TPS62067-Q1 1.05V/2A

i.MX8M PWR

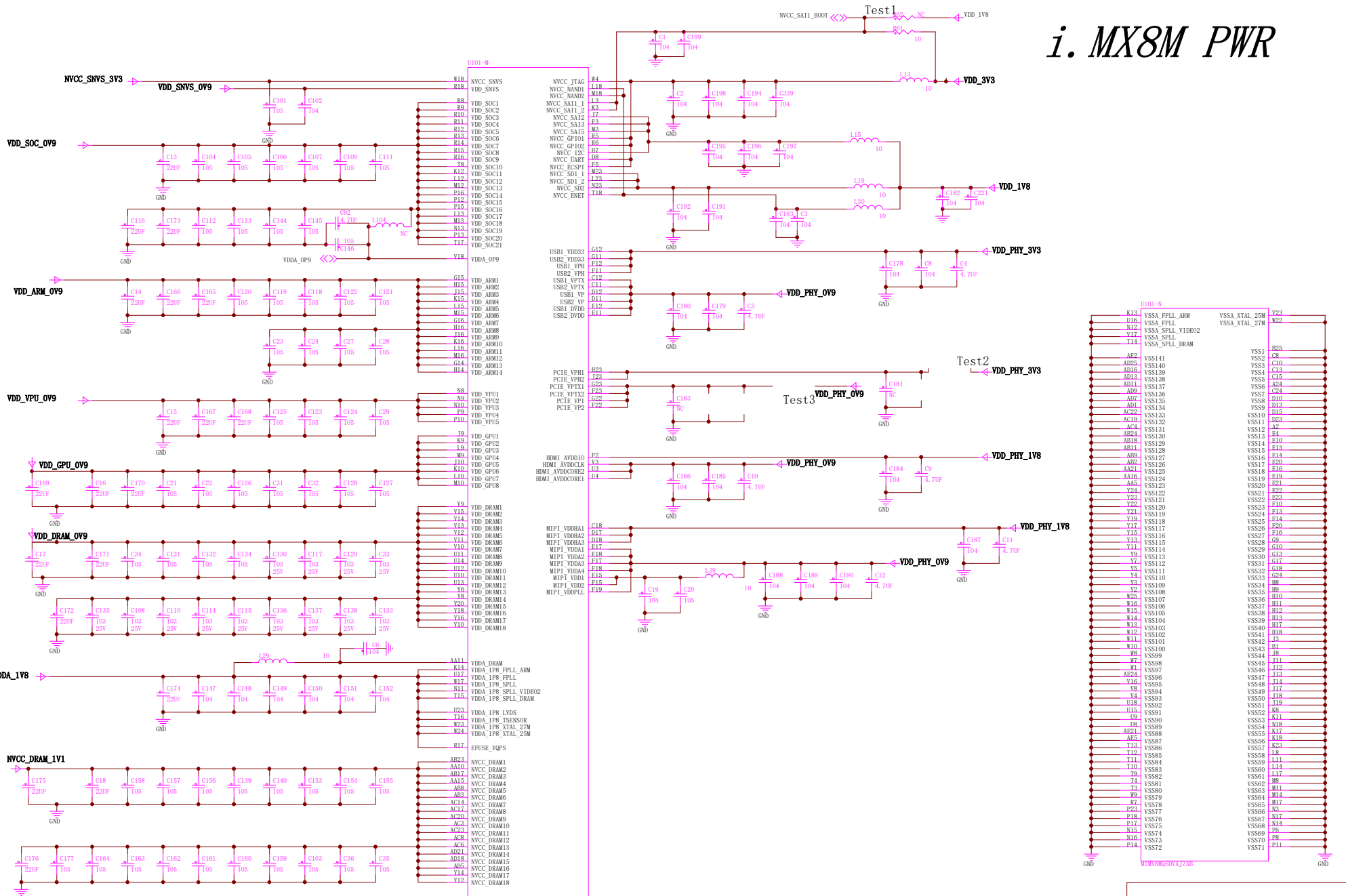

Purism

Drawing Title: Librem 5		
Page Title: CPU POWER		
Rev: v1.0.2	Date:	Design by:
Sheet 3 of 21		

MIMX8MQ6DVAJZAA

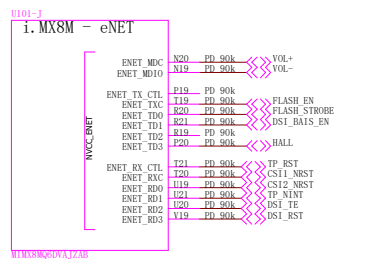
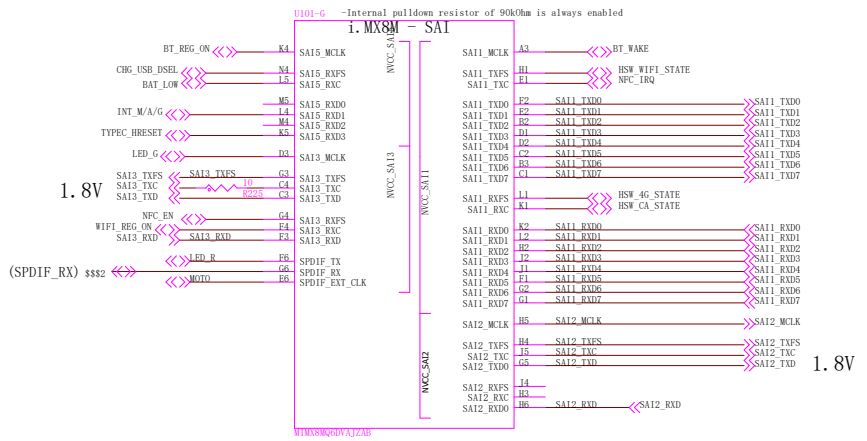
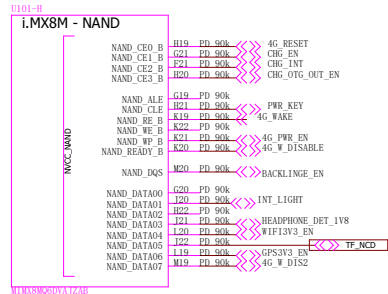

UART DBG

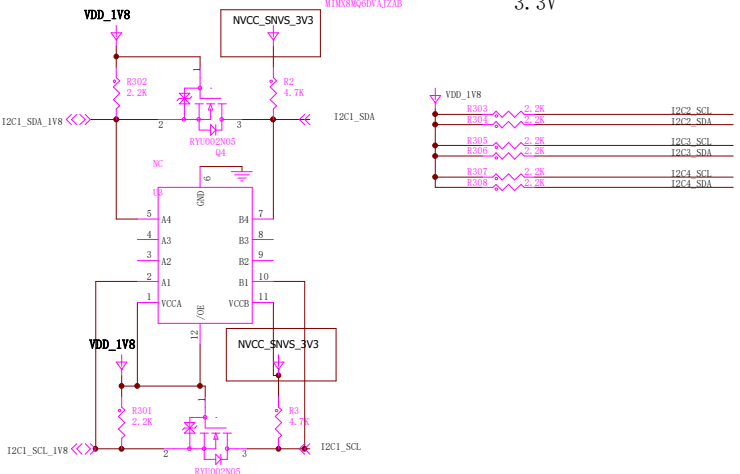
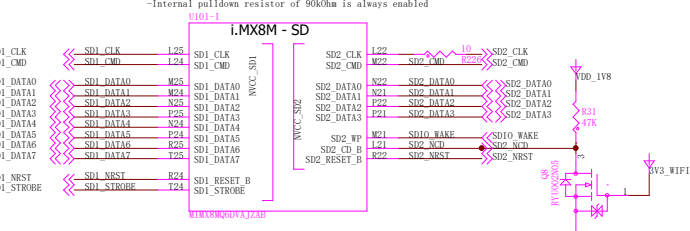
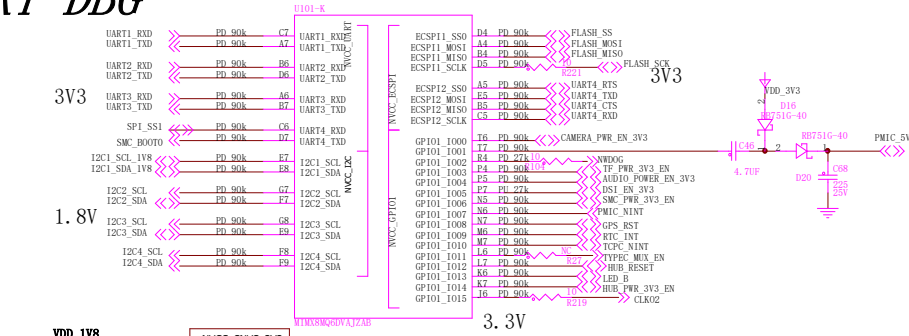

Purism		
Drawing Title: Librem 5		
Page Title: CPU I0		
Rev: v1.0.2	Date:	Design by:
Sheet 5 of 21		

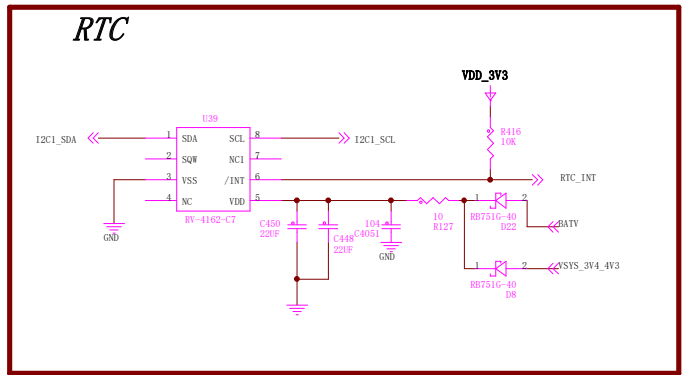

JTAG Debug

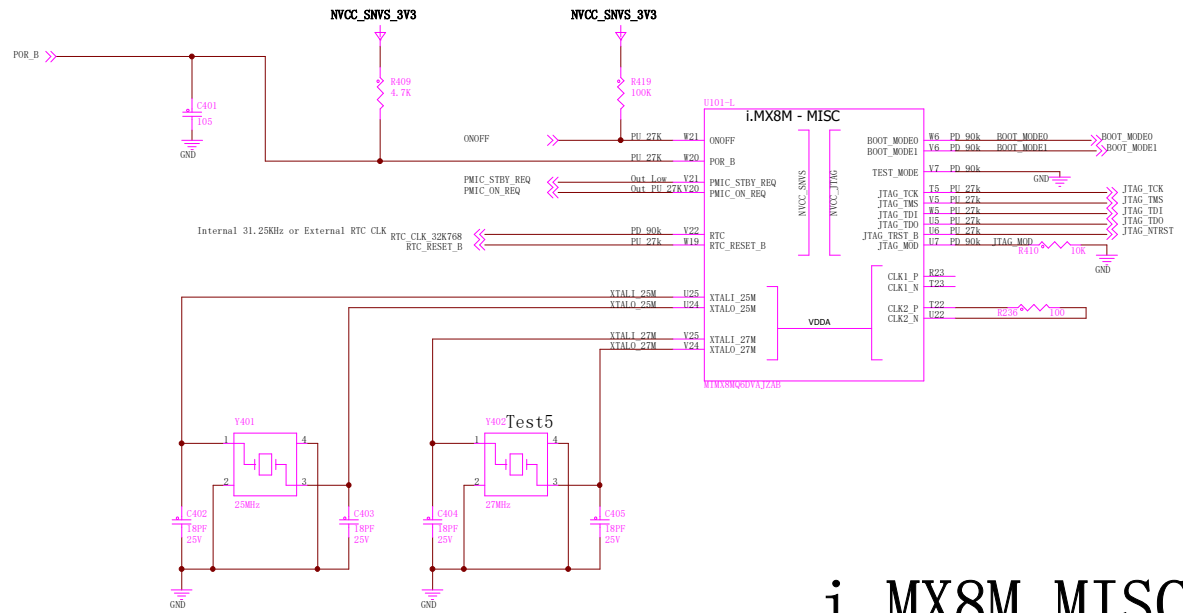

i.MX8M MISC

Purism		
Drawing Title: Librem 5		
Page Title: CPU MISC, RTC		
Rev: v1.0.2	Date:	Design by:
		Sheet 6 of 21

i. MX8M PHY

USB_RESREF: Attach a 200-Ω 1% 100-ppm/C precision resistor-to-ground on the board.
 MIPIDSI_REXT: 15k-Ω
 PCIe: 200-Ω ±1% ± 100 ppm/°C precision resistor to-ground on the board.
 HDMI: a 499Ω (±1% tolerance) resistor to-ground on the board

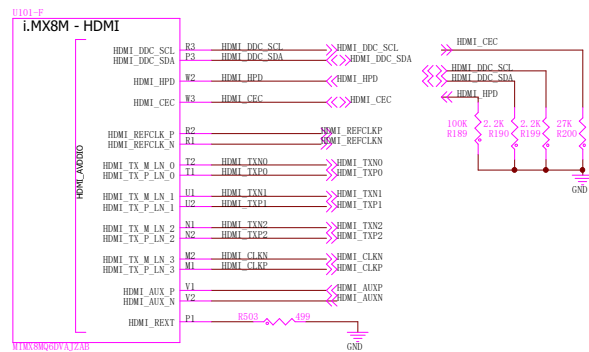
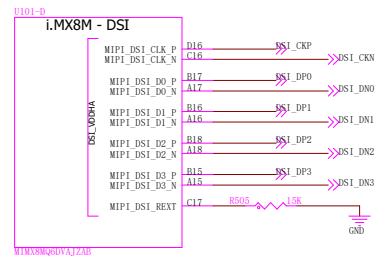
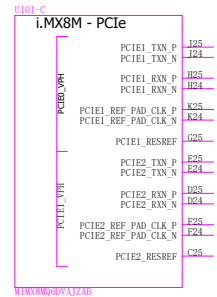
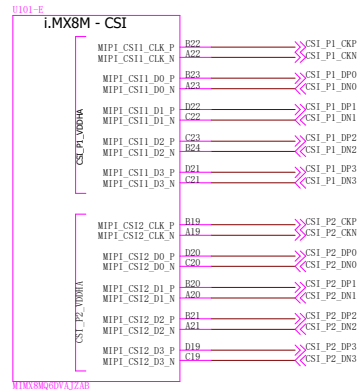

AC coupled differential low swing clock (HCSL levels)

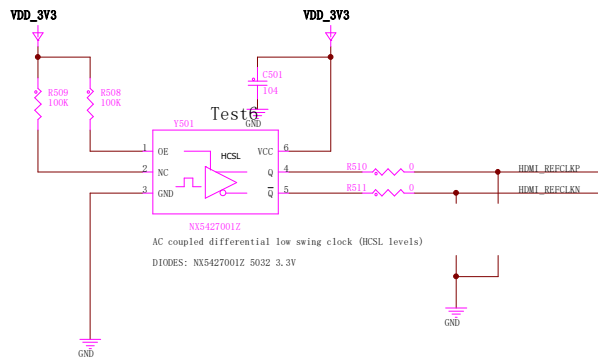
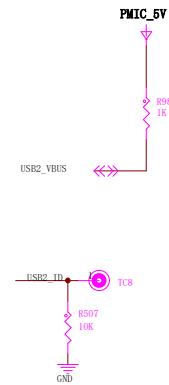
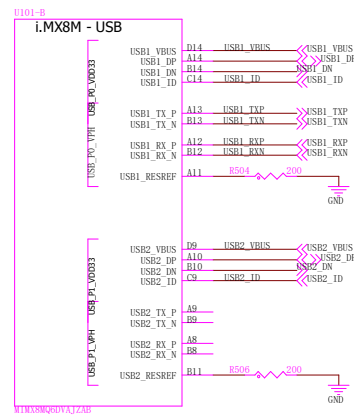

Purism		
Drawing Title: Librem 5		
Page Title: CPU PHY		
Rev: v1.0.2	Date:	Design by:
		Sheet 7 of 21

eMMC 5.0 Footprint

VDD_3V3
eMMC/TF co-Layout

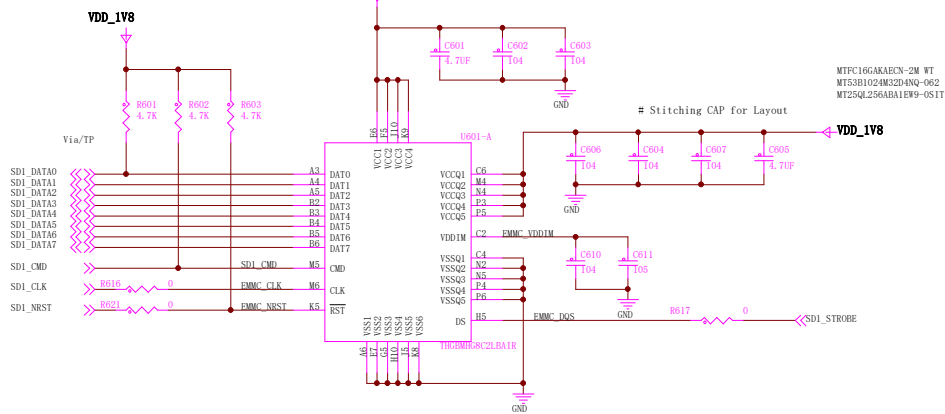

MTPC16G6AECN-2M WT
MT33B1024E2D4NQ-062
MT25QL256ABA1E1W9-051T

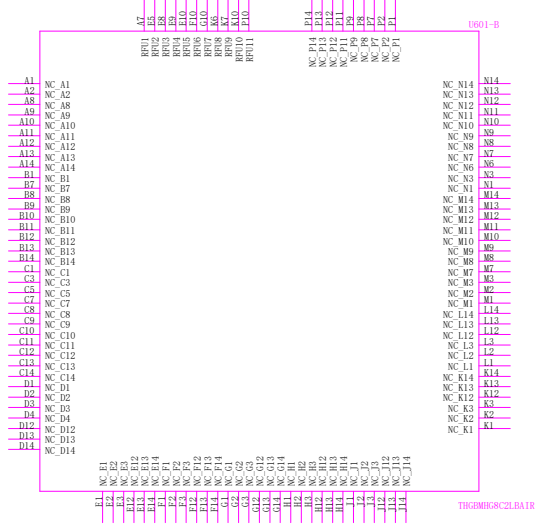

Purism		
Drawing Title: Librem 5		
Page Title: EMMC		
Rev: v1.0.2	Date:	Design by:
		Sheet 8 of 21

SYS PMIC/PWR

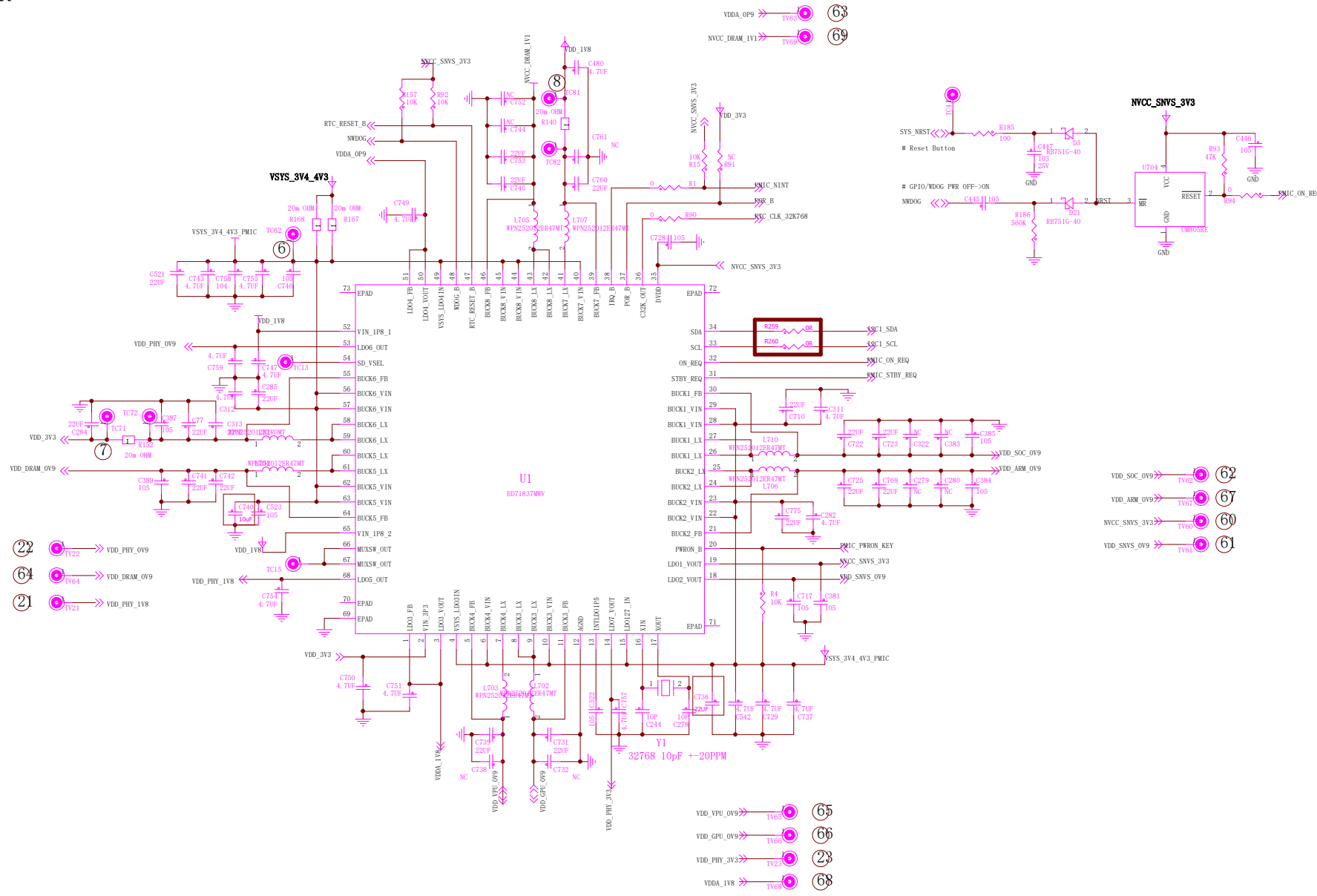

Purism		
Drawing Title: Librem 5		
Page Title: PMIC		
Rev: v1.0.2	Date:	Design by:
Sheet 9 of 21		

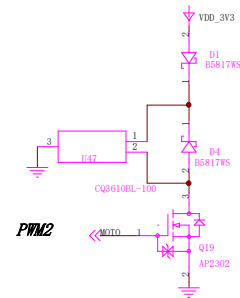
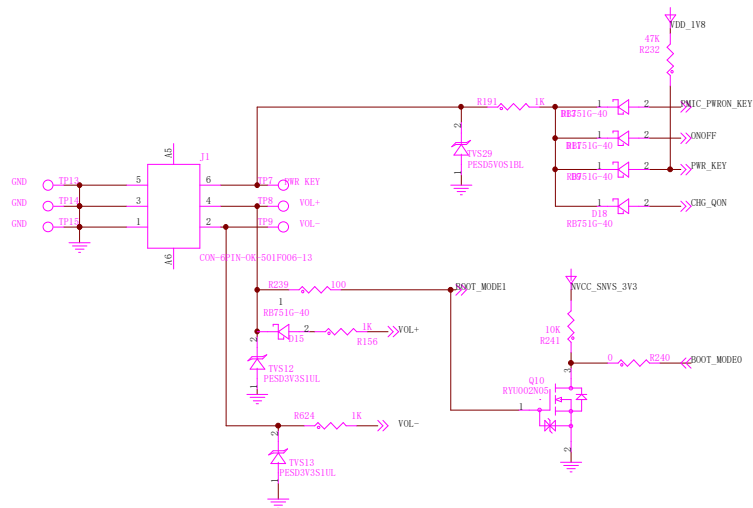

Boot Device: eMMC

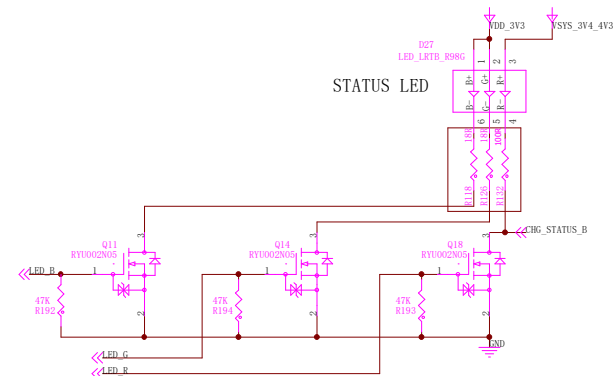
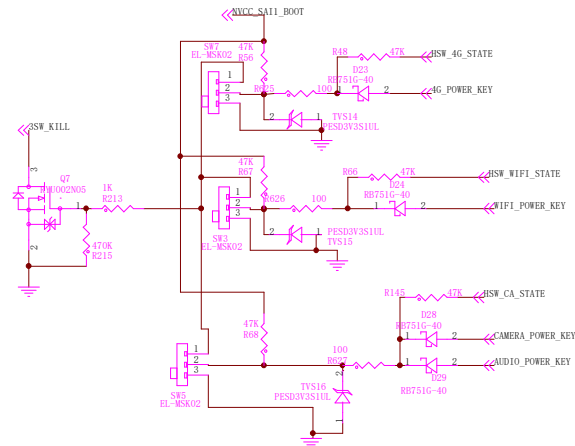
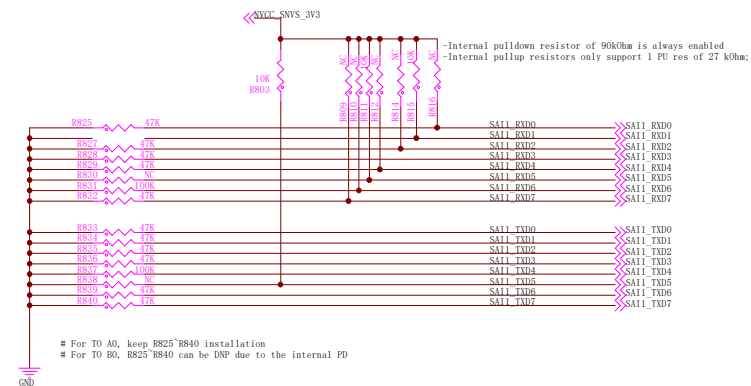

Purism		
Drawing Title: Librem 5		
Page Title: BOOT CFG		
Rev: v1.0.2	Date:	Design by:
		Sheet 10 of 21

USB3.0/2.0 TYPE-C/HOST

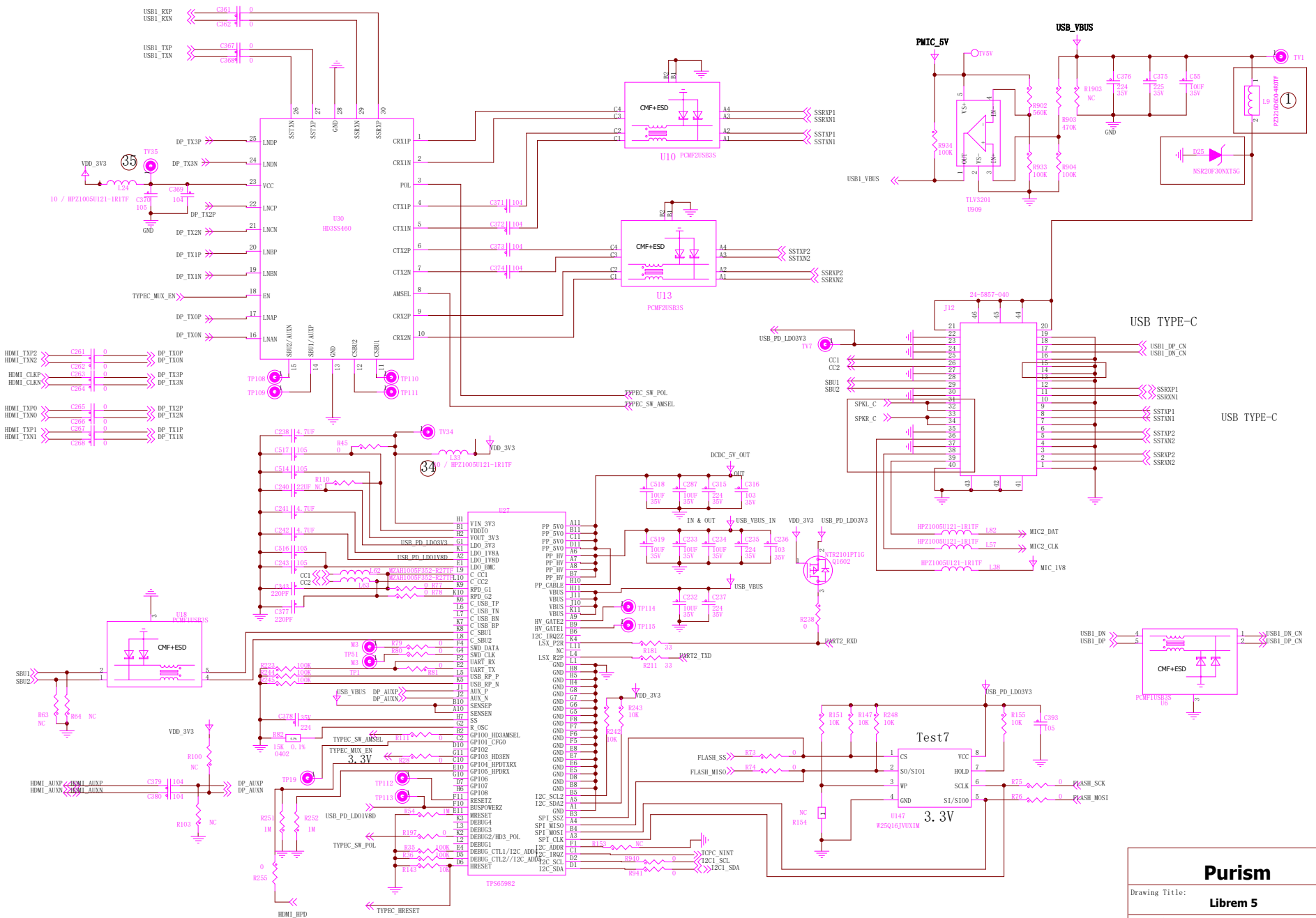

Purism		
Drawing Title: Librem 5		
Page Title: USB TYPE C		
Rev: v1.0.2	Date:	Design by:
Sheet 11 of 21		

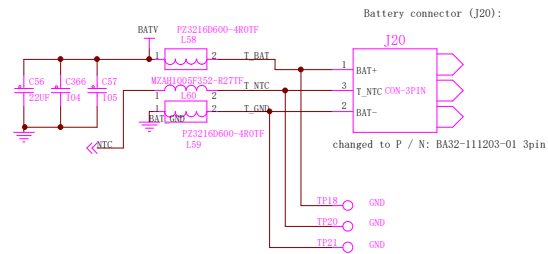
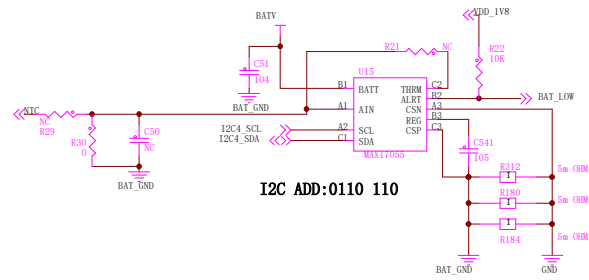
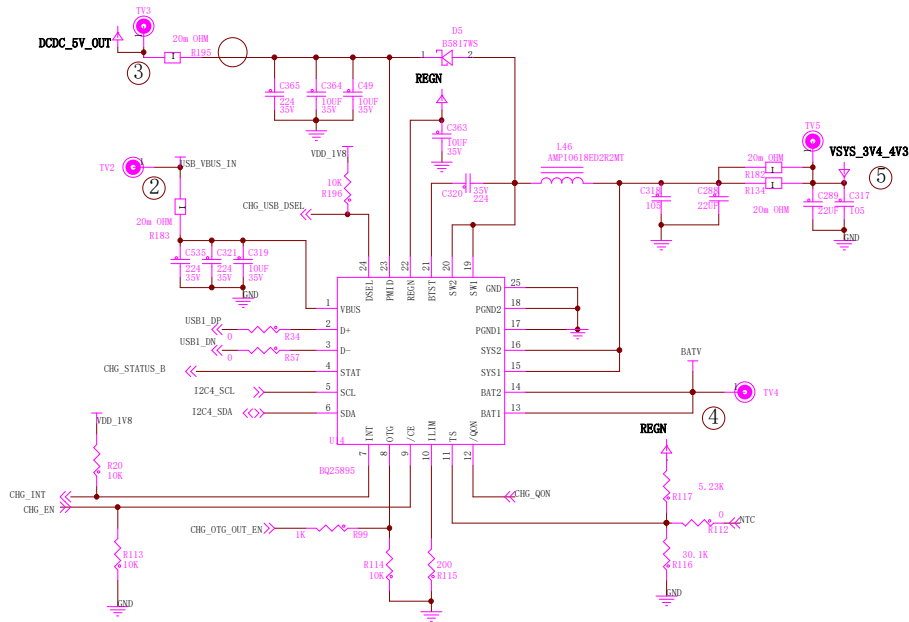

Purism		
Drawing Title: Librem 5		
Page Title: CHARGE, BAT, LED		
Rev: v1.0.2	Date:	Design by:
		Sheet 12 of 21

Sensor

Light Sensor

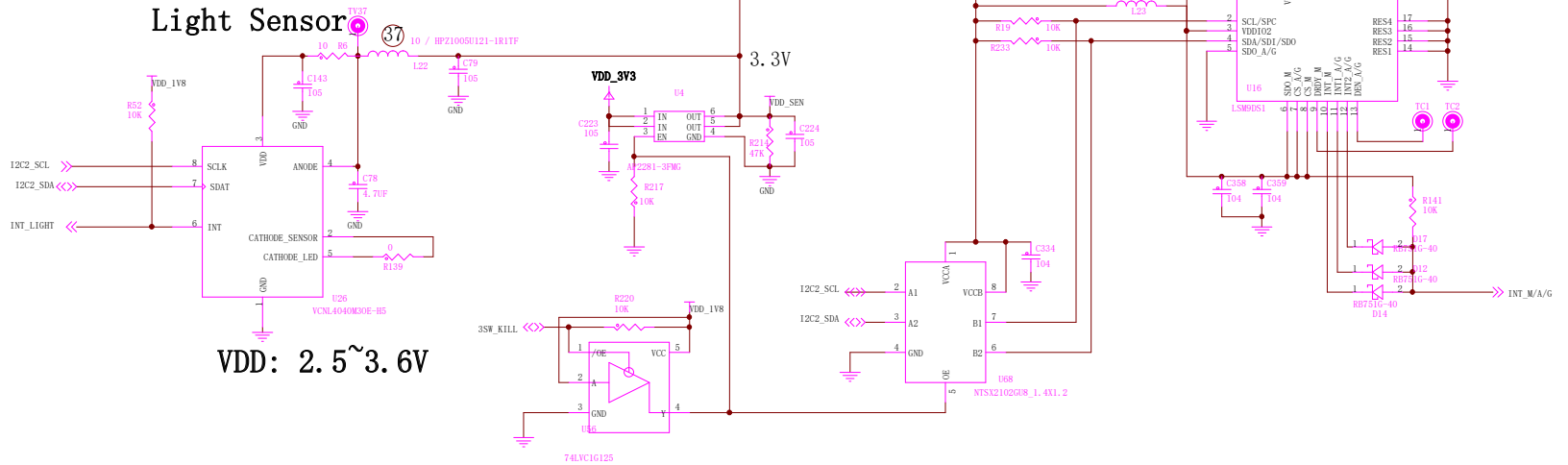

HALL Sensor

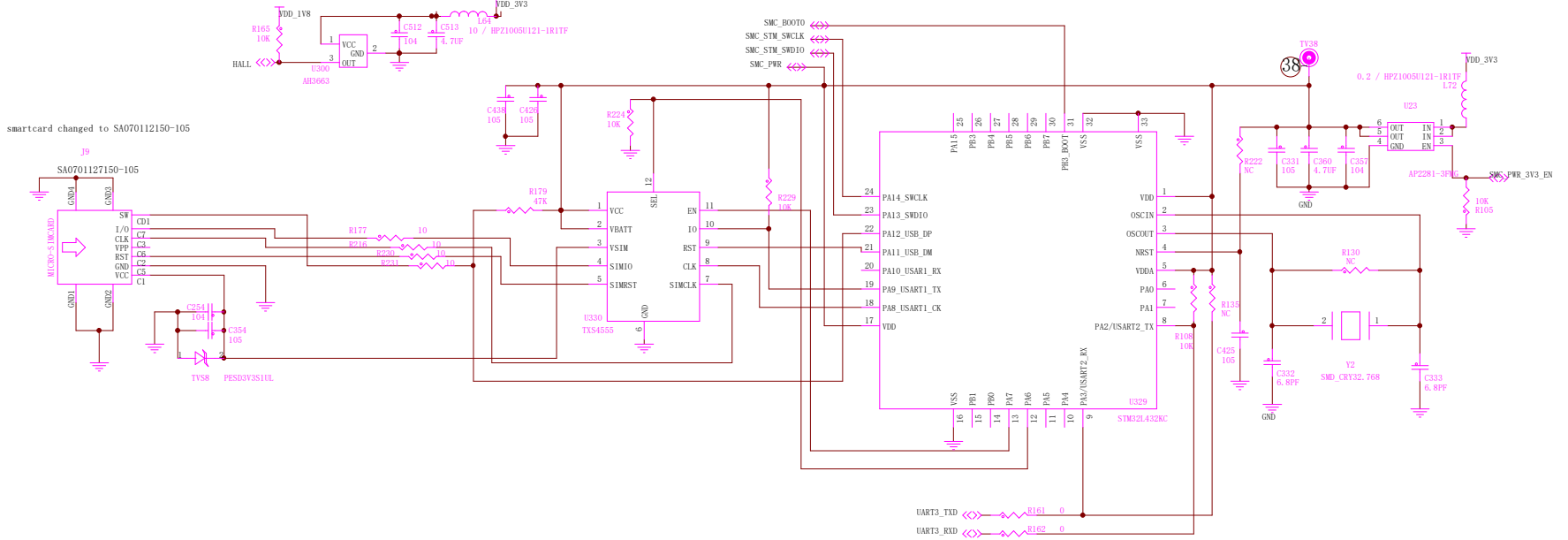

Purism

Drawing Title:		
Librem 5		
Page Title:		
SENSOR, SMART CARD		
Rev:	Date:	Design by:
v1.0.2		
Sheet 13		of 21

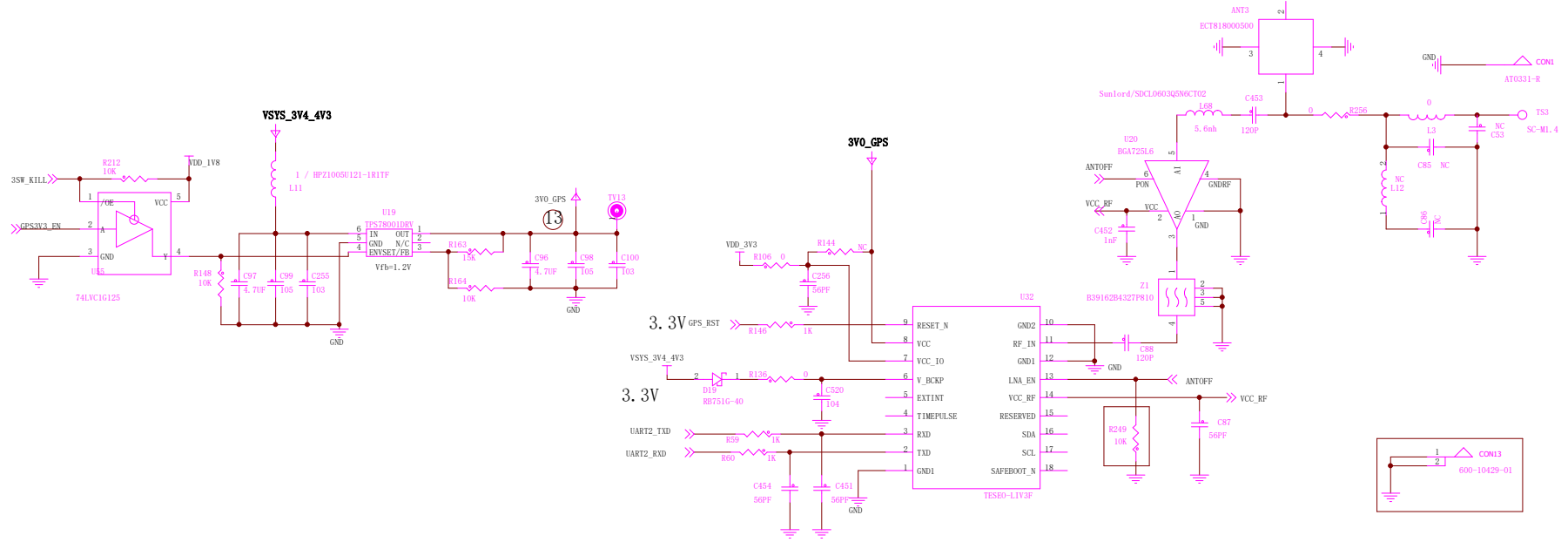

EXT CON

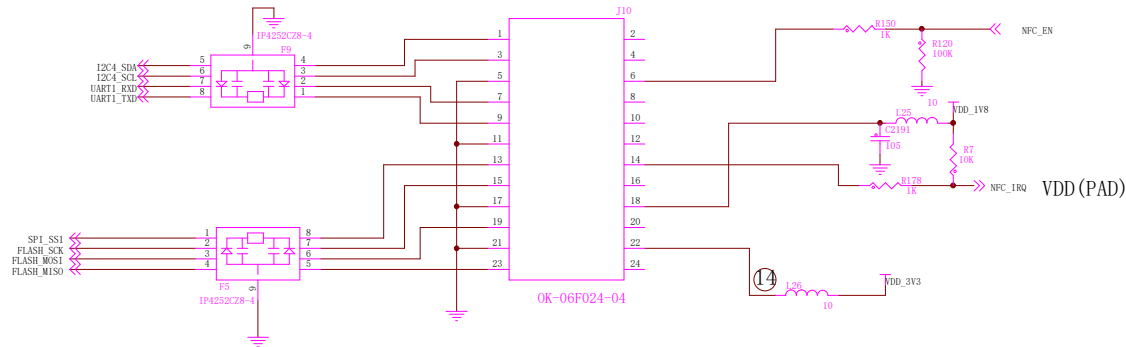

Purism		
Drawing Title: Librem 5		
Page Title: GNSS		
Rev: v1.0.2	Date:	Design by:
		Sheet 14 of 21

WiFi/BT 802.11a/b/g/n/ac + Bluetooth 4.1/ EDR

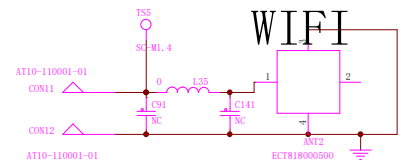
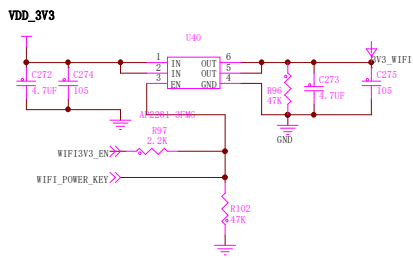
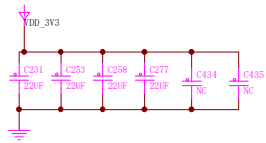
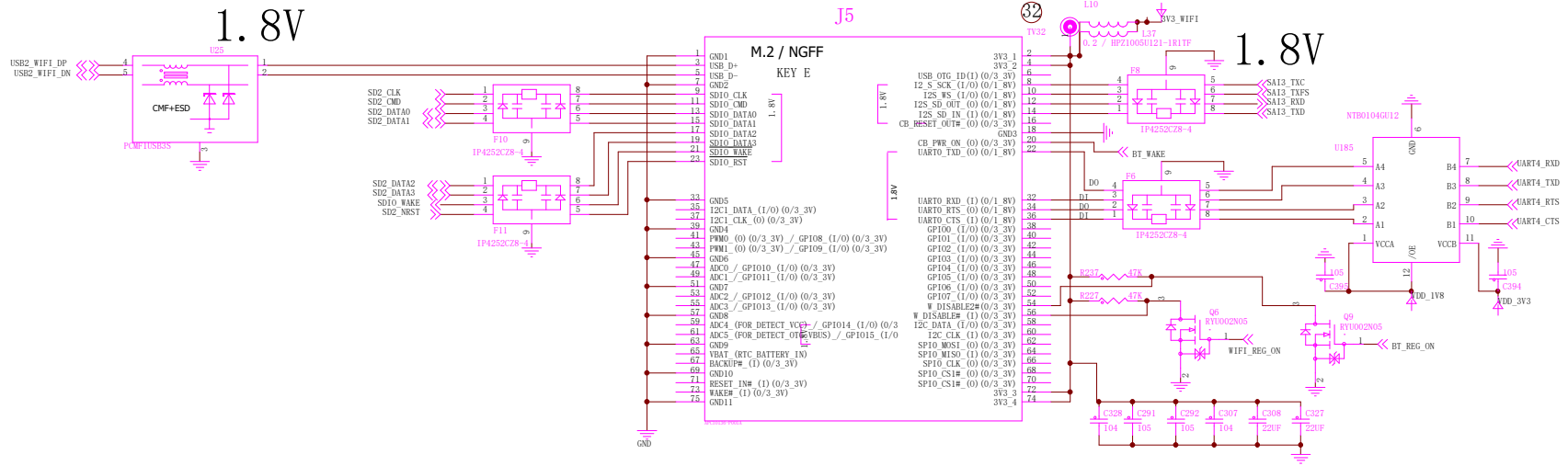

Purism		
Drawing Title: Librem 5		
Page Title: WIFI, BT		
Rev: v1.0.2	Date:	Design by:
		Sheet 15 of 21

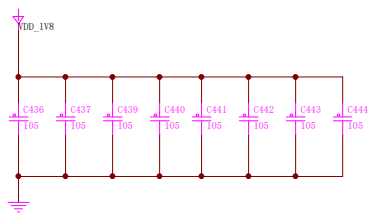
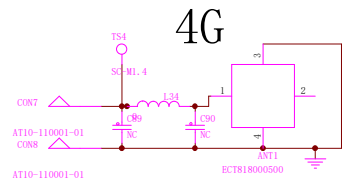
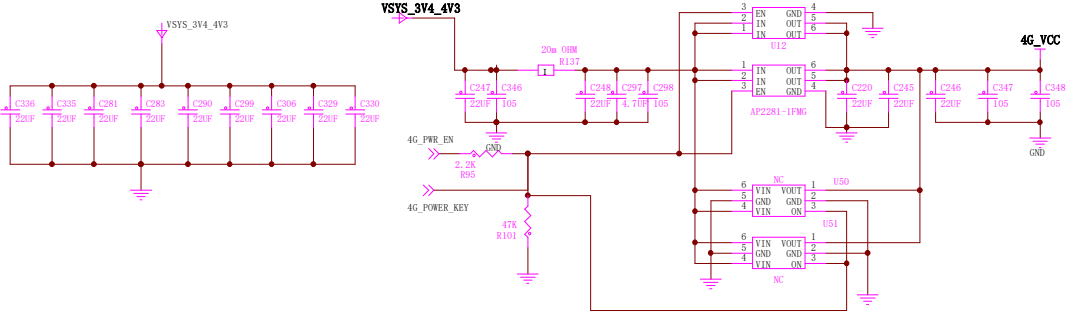
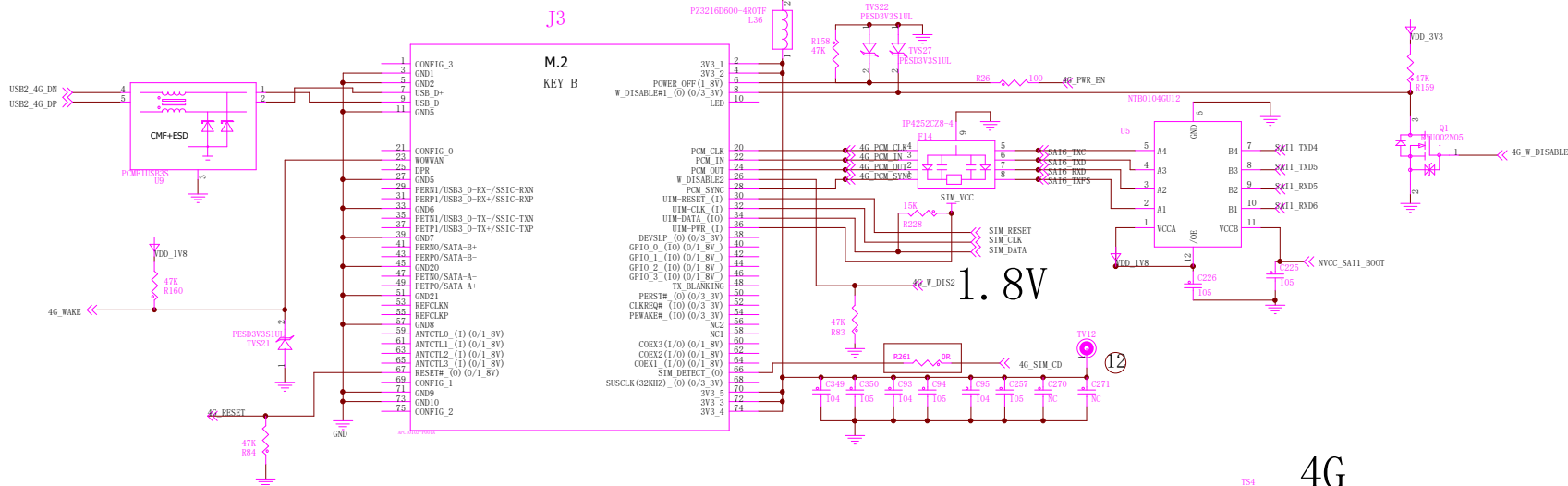

Purism		
Drawing Title: Librem 5		
Page Title: 4G		
Rev: v1.0.2	Date:	Design by:
Sheet 16 of 21		

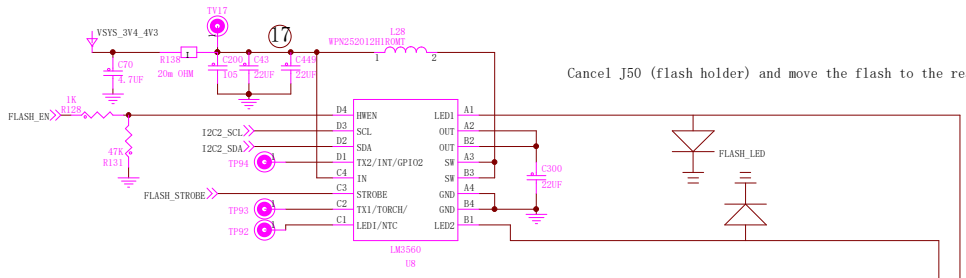

Cancel J50 (flash holder) and move the flash to the rear camera FPC

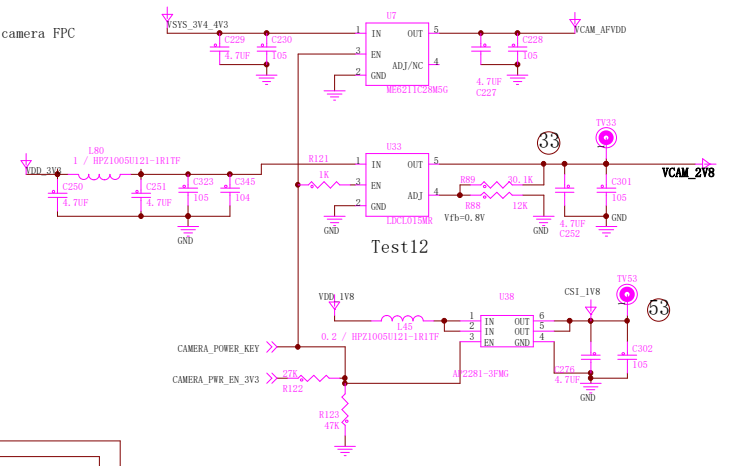

Test12

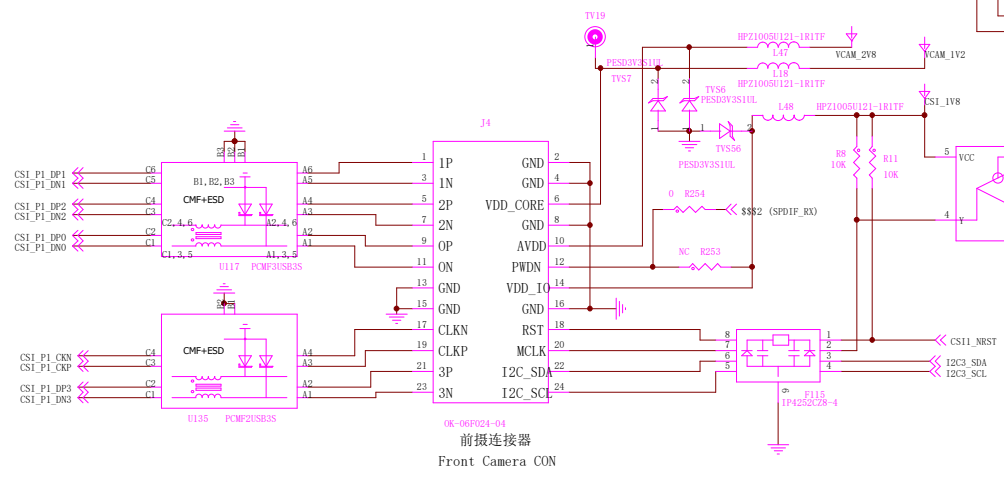

0K-06F034-04
前摄连接器
Front Camera CON

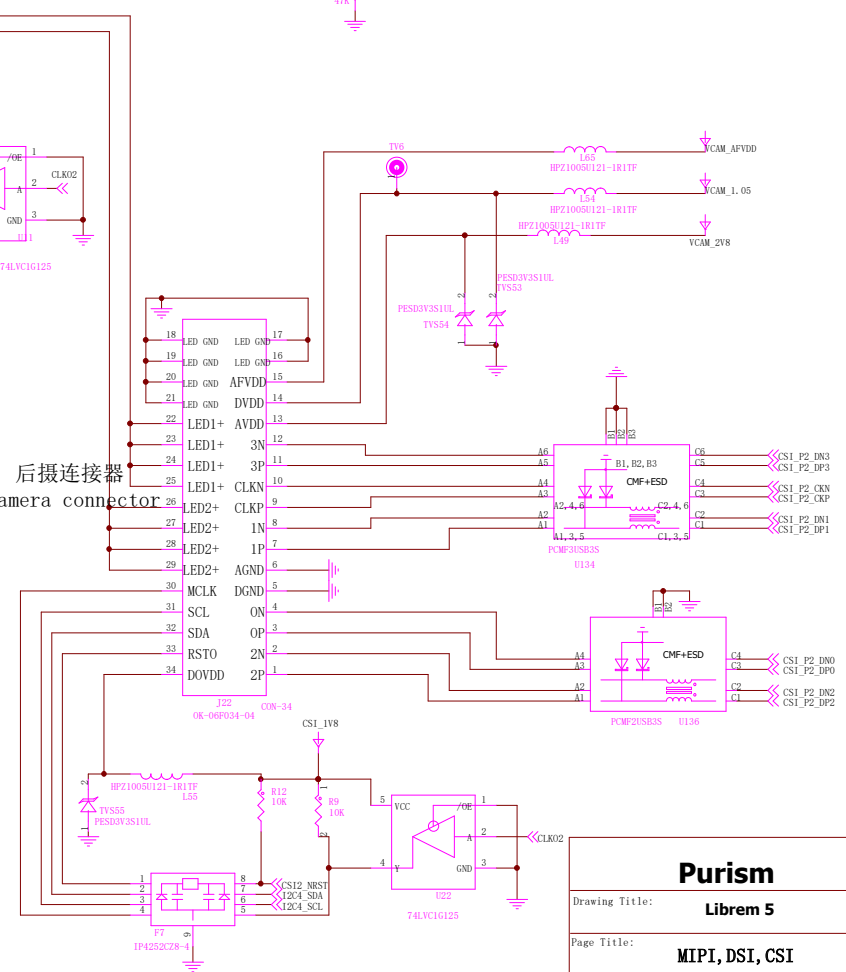

后摄连接器
Rear camera connector

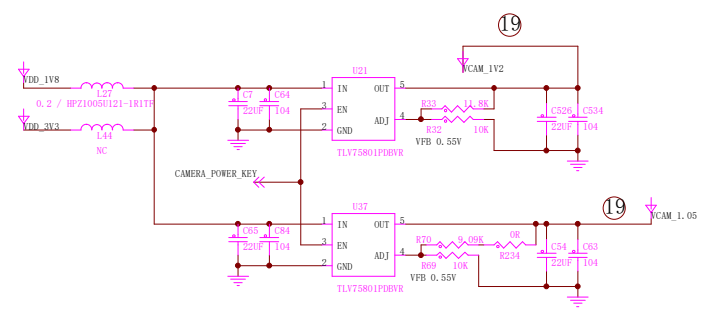

Purism		
Drawing Title: Librem 5		
Page Title: MIPI, DSI, CSI		
Rev: v1.0.2	Date:	Design by:
Sheet 17 of 21		

DSI LCD IF

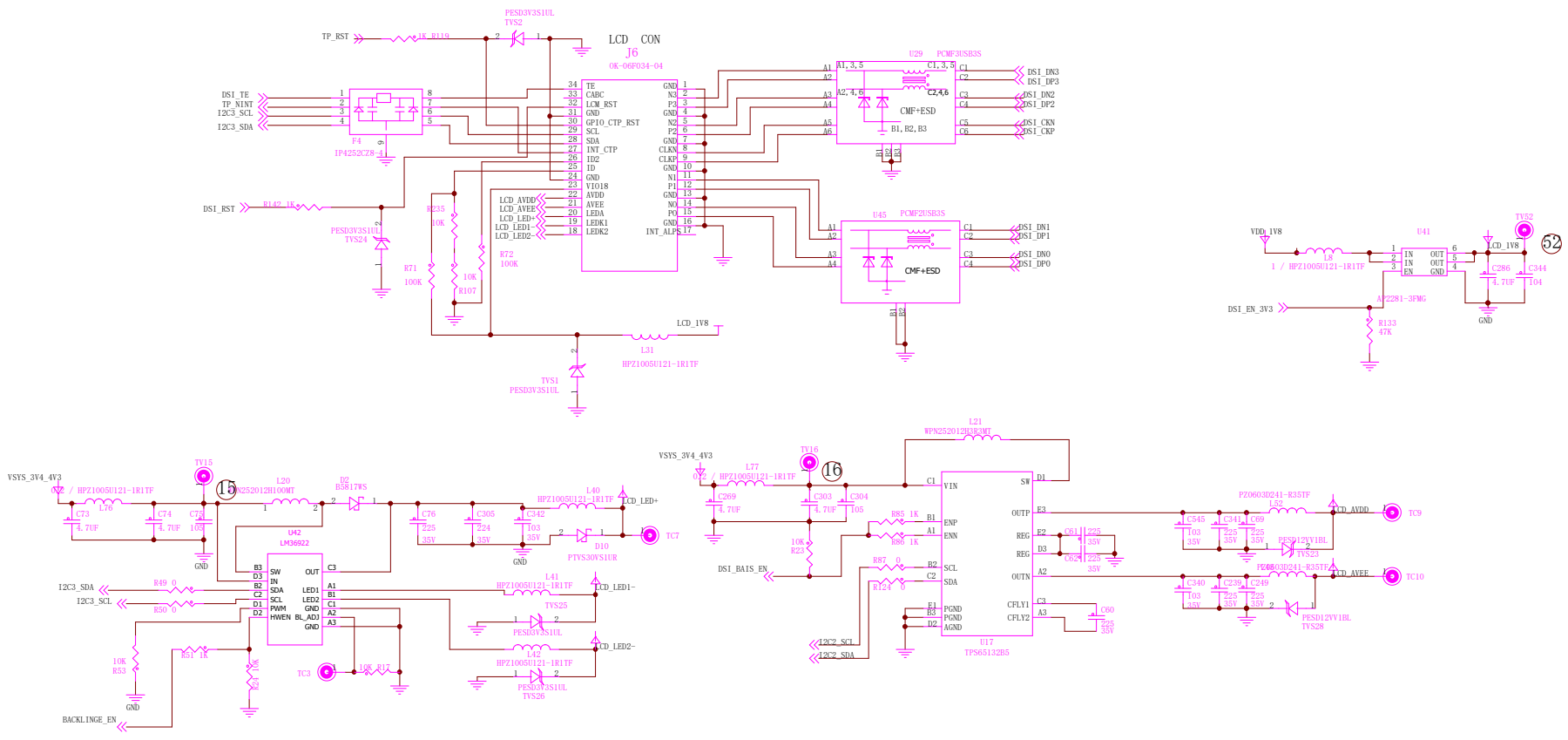

Purism		
Drawing Title: Librem 5		
Page Title: MICROSD, MOTO		
Rev: v1.0.2	Date:	Design by:
		Sheet 18 of 21

USB HUB + SDIO BRIDGE

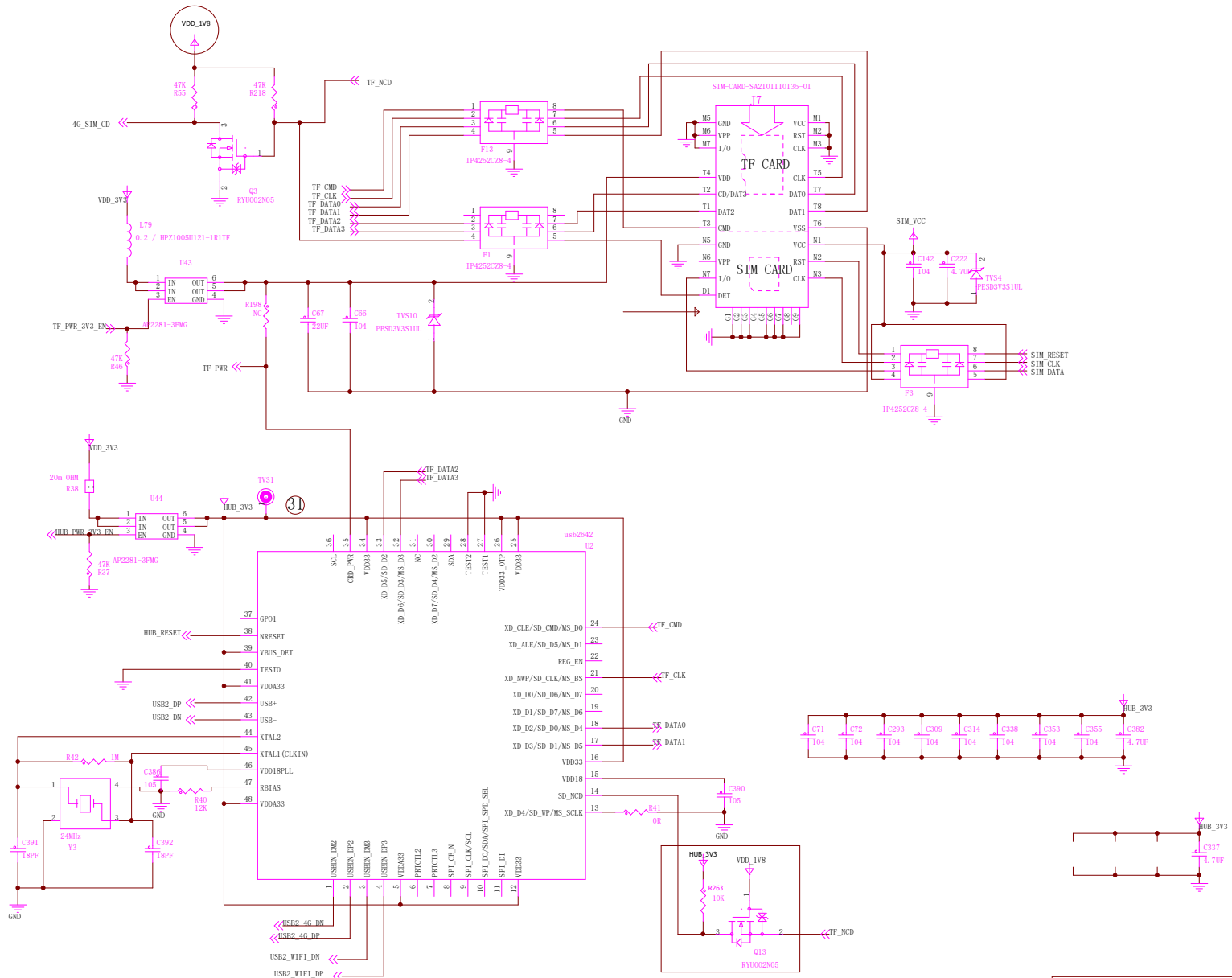

Purism		
Drawing Title: Librem 5		
Page Title: USB HUB		
Rev: v1.0.2	Date:	Design by:
Sheet 19 of 21		

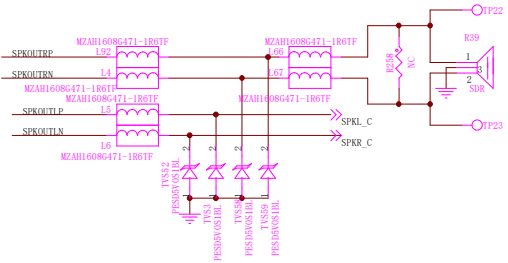
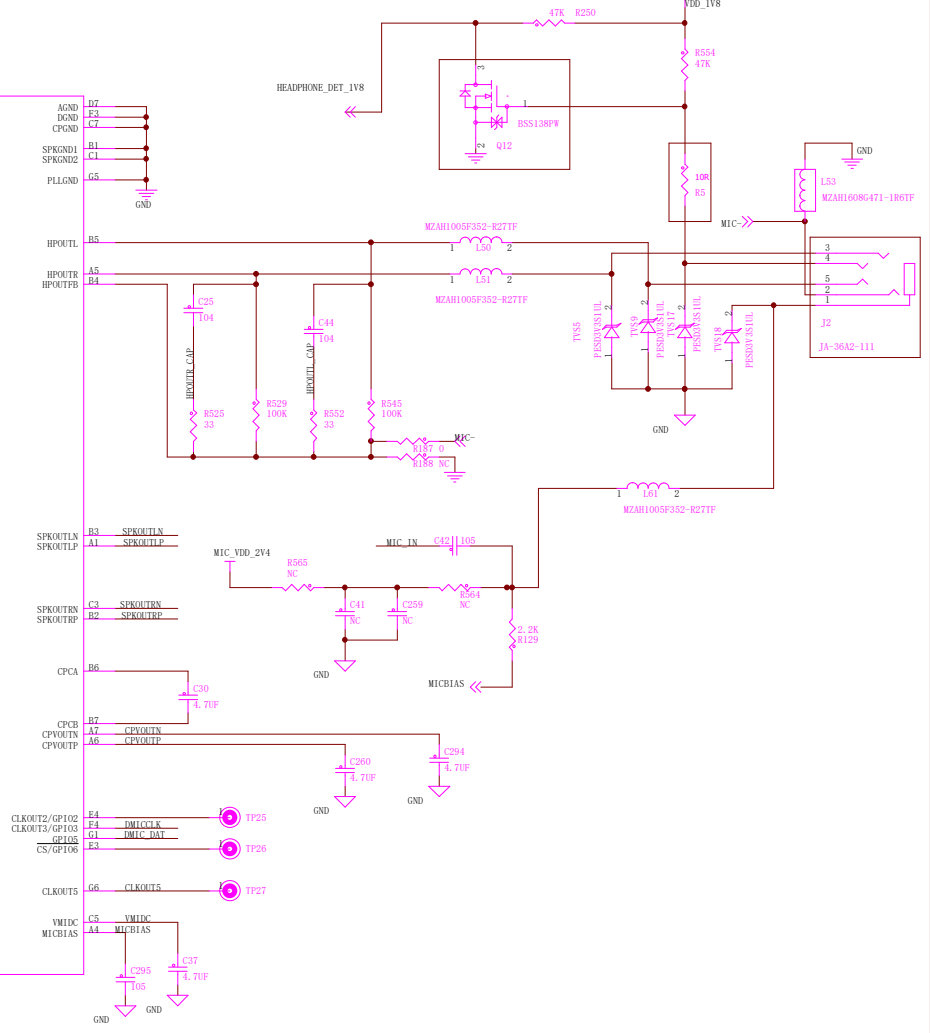
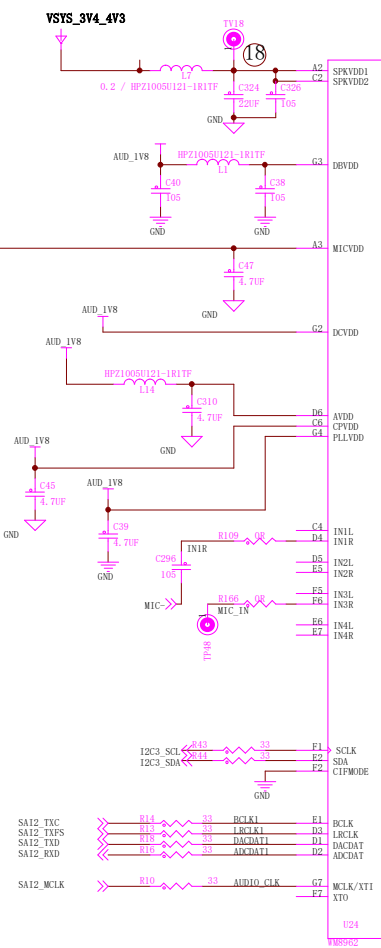
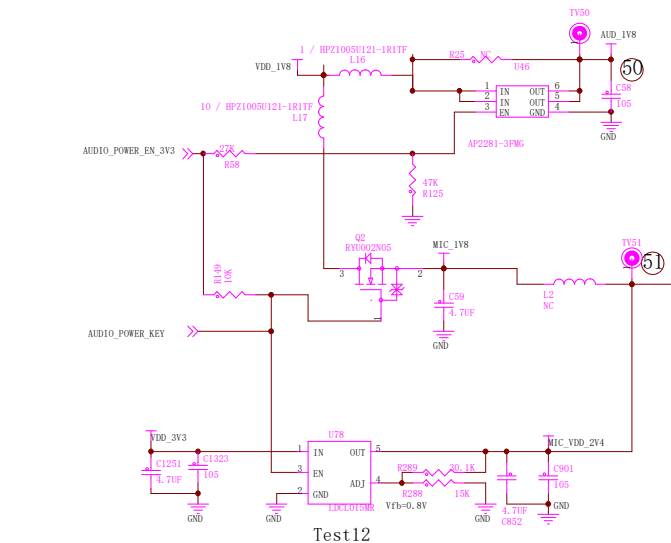

Purism		
Drawing Title: Librem 5		
Page Title: AUDIO		
Rev: v1.0.2	Date:	Design by:
		Sheet 20 of 21

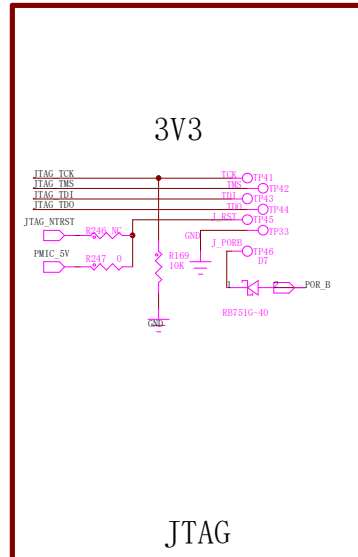
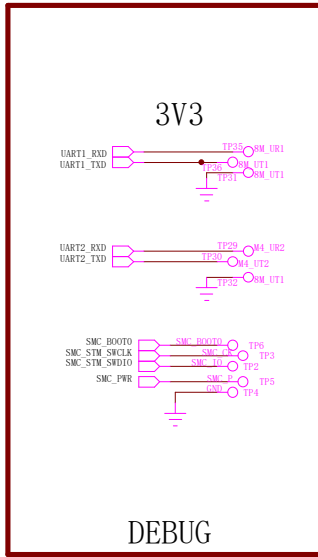
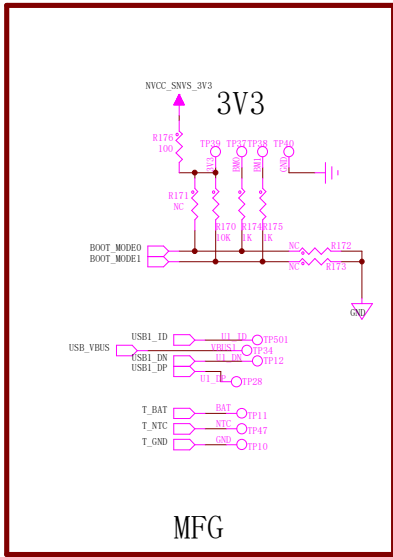

M2 module SCREW

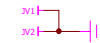
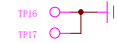

BMODE[1:0]	BOOT TYPE
00	Boot From Fuses
01	Serial Downloader
10	Internal Boot (Development)
11	Reserved

SCREW

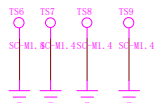
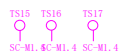

Shielding Case

Shielding Case Hold

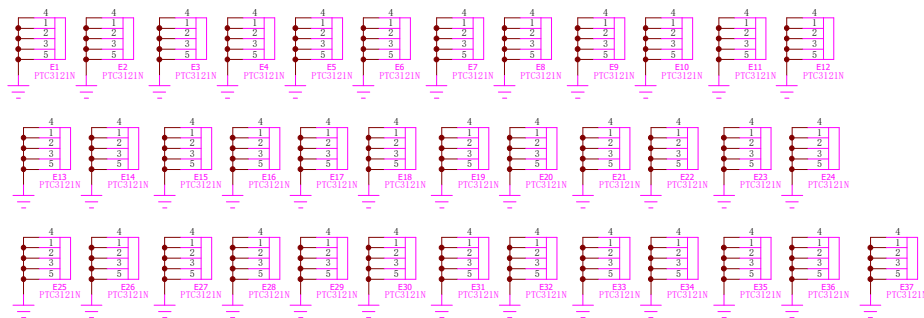

Purism		
Drawing Title: Librem 5		
Page Title: DEBUG		
Rev: v1.0.2	Date:	Design by:
		Sheet 21 of 21